



艾特技减速机
ATG REDUCER

ATG智造 慧及全球
Wisdom Made IN ATG Wisdom The World

精密行星减速机
PRECISION PLANETARY REDUCER



ATG智造 慧及全球
免費諮詢: 400-0572-809



ATG REDUCER

艾特技减速机

ATG智造 慧及全球
免费咨询: 400-0572-809

减速机专业制造商

Reducer professional manufacturer

信念

- 企业宗旨：用户至上，信誉取胜，质量优良，服务优质。
- 经营理念：质量——形象的基础，科技——腾飞的关键
管理——永恒的主题，创新——发展的源泉
靠员工管理企业，靠科技提高素质，
靠质量赢得市场，靠创新促进发展。
- 团队意识：我靠企业生存，企业靠我发展；我为企业尽力，企业为我谋利。
- 企业作风：实干，高效，文明，拼搏。求真、务实，勤奋，高效。

质量

- 企业精神：爱厂敬业，开拓进取，敬业尽责，拼搏创新，敬业奋斗，开拓创新。
- 职业道德：用户是衣食父母，服务是基本职责。用户至上，服务第一。
- 企业形象：依法经营，管理科学，从业文明，作风过硬，服务优质，质量优良，技术精湛，勇于创新。
- 质量方针：技术先进，管理科学，工程、产品优质，诚信重诺，服务到位。
- 企业信念：走好今日创业路，办好明天发展事，走创业之路，谋发展大计，谱辉煌篇章。

方针

- 经营战略：人才战略，品牌战略，创新战略，市场开发战略。
实施人才、品牌、创新和市场开发战略，巩固、
提高建筑安装水平，发展、壮大加工制造能力。
- 企业价值观：永不满足，争创一流，完善自我，不断发展。
- 企业环境：内部关系和谐，全厂上下同心协力；外部关系顺畅，四面八方助我发展。
- 企业哲学：管理以人为本，服务以质为先，作风以硬为优，效益以高为佳。
- 行动口号：以实干求生存，以创新谋发展。



Wisdom Made
IN ATG
Wisdom The World
ATG智造,慧及全球

ATG智造 慧及全球
免費諮詢: 400-0572-809



INTRODUCTION

台湾君益机械股份有限公司，苏州仟德亿机电有限公司隶属于台湾君益机械，君益机械创立于1972年3月，并于1989年在美国洛杉矶成立分公司ATRUMPMACHINERYINC.，1995年通过了商品检验局ISO9002认证，2003年通过ISO9001质量认证，且通过欧洲CE的规范测试，使产品得以在欧洲销售，多年来于外销市场深获好评并获奖无数，足迹遍布全球30余国；

君益股份有限公司专业从事高科技的各种减速马达及螺旋齿轮减速机，蜗杆蜗轮减速机，行星式减速机的设计、研发、生产。近年来肩负着顾客们对产品质量与价格的追求，不断地在提高减速机的高性能、实现效率的最大化和提供广泛的技术资源等方面做着不懈的努力。

公司奉行『质量第一、顾客满意』及『勤、诚、信』的经营理念，不断吸纳专业人才，使得公司始终拥有一批掌握业界高端技术的科技人才。公司以积极务实的作风，借鉴各种先进的管理经验，不断实现自我完善，建立起良好的企业文化。近年来有感于中国大陆市场的未来性及重要性，因此在大陆江苏省立分公司（苏州仟德亿机电有限公司，以供应大陆地区广大客户的需求。

ATG智造 慧及全球

ABOUT US

关于我们



Taiwan Jun Yi Machinery Co., Ltd., Suzhou thousand Deyi Electrical Co., Ltd. under the Taiwan Jun Yi Machinery , Jun Yi Machinery was founded in March 1972, and in 1989 Established in the United States Los Angeles branch ATRUMPMACHINERYINC., 1995 passed the Commodity Inspection Bureau ISO9002 certification in 2003 through the ISO9001 Quality certification, and through the European CE test specifications, so that products can be sold in Europe, deep acclaim and won numerous awards over the years in the export market, global footprint 30l country;

Jun Yi Co., Ltd. specializes in a variety of high-tech gear motor and helical gear reducer, worm gear reducer, planetary gear design, development, produce. In recent years, shouldering the customers on product quality and price of the pursuit of continuously improving high-performance gear, and maximize efficiency and provide a wide range of technical Resources and other aspects of making unremitting efforts.

The company pursues "quality first, customer satisfaction" and "diligence, honesty, trust" business philosophy, and constantly recruit professionals, so that the company always has a master industry Scientific and technological talents of high-end technology. Companies with a positive and pragmatic style, learn advanced management experience, and constantly self-improvement, and establish a good corporate culture. near Responding to future years and the importance of the Chinese mainland market, so the continent, Jiangsu Provincial Branch (Suzhou thousand Deyi Electrical Co., Ltd., the mainland to supply the majority of passengers Household needs.

一流的质量来自
一流的生产设备

LIEBHERR



ATG智造 慧及全球

Production

生产设备

每一件产品,我们都用心制造出来
Each product, We are all made by heart

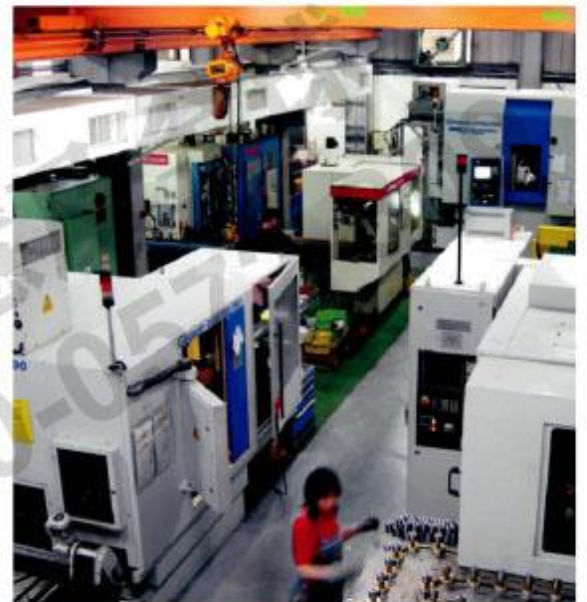

“精”以修身，
“检”以养德。

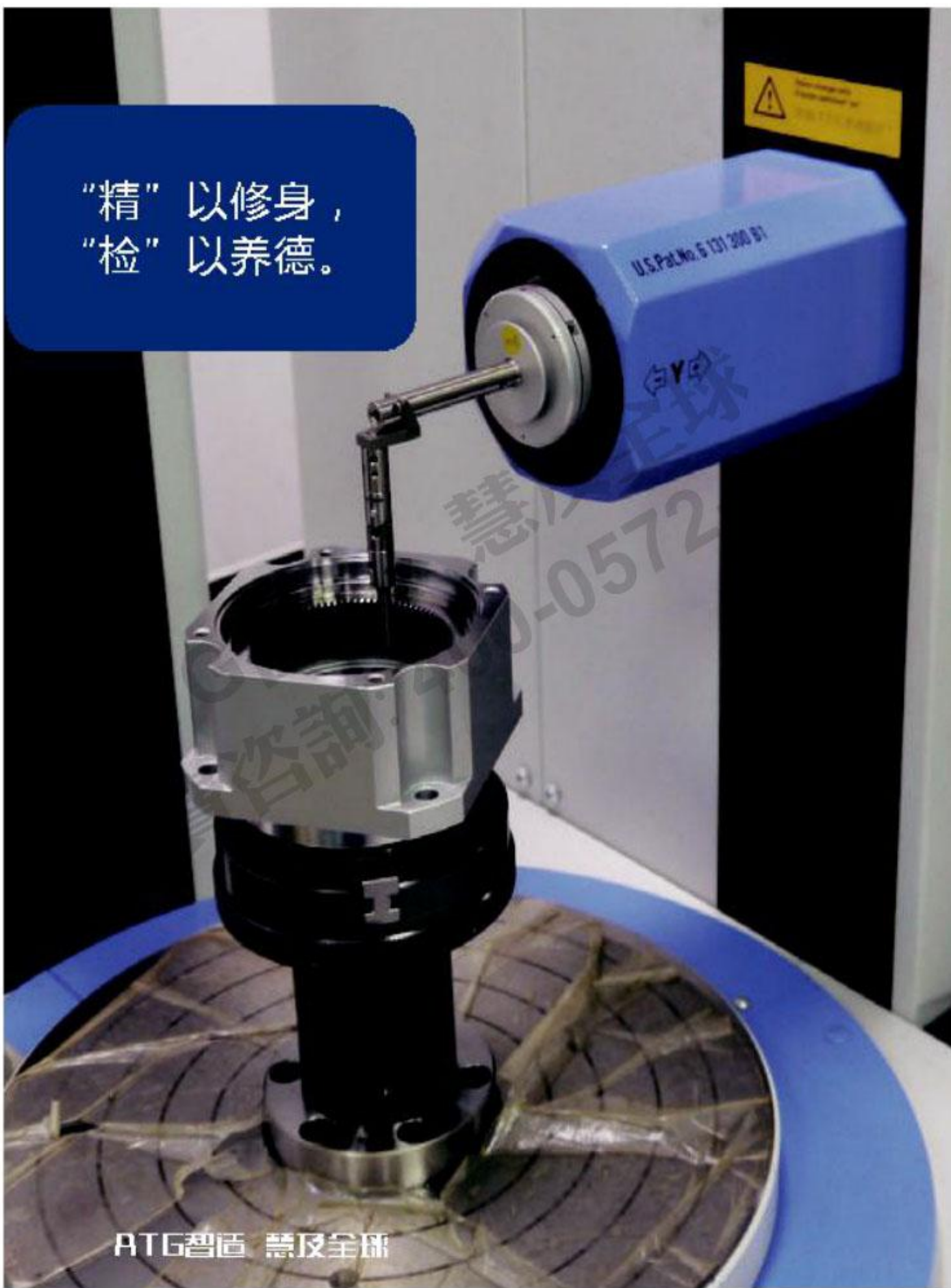

RTG智造 慧及全球

Testing Equipment

检测设备

精检于心，质控未来
Check in heart, Quality in the future



ATG
ATG REDUCER
艾特技减速机



Heat Treatment

热处理

独特真空渗碳齿轮兼具表面硬度与心部韧性，不但耐磨耗，且能在承受重负载的情况下，保持高啮合精度。

Unique vacuum carburization treatment has the features of high surface hardness and interior toughness. It is hard-wearing and hard-tearing. It will keep good engagement under heavy loading.

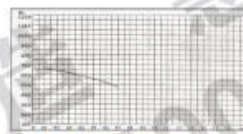

*硬度分布图 Hardenability curve



金相组织相片 Metallograph



High Precision Gear Machining

高精度齿轮加工

行星齿轮及太阳齿轮材料采用高级之镍铬钼合金钢(SNCM220),切削加工后,经渗碳热处理至硬度57~60HRC,再进行齿面研磨,确保齿轮精度在DIN6级以内,比只有表面的氮化处理,获得最佳的耐磨耗和耐冲击韧性,寿命更长。

The planetary gear and sun gear are manufactured from high quality NI-Cr-Mo alloy steel (SNCM220), precision machined and carburized to hardness 57-60HRC. Precision teeth grinding assures gear accuracy reaches DIN6 class. It provides better wear resistance, impact resistance and longer service life than gears with only surface nitrided.

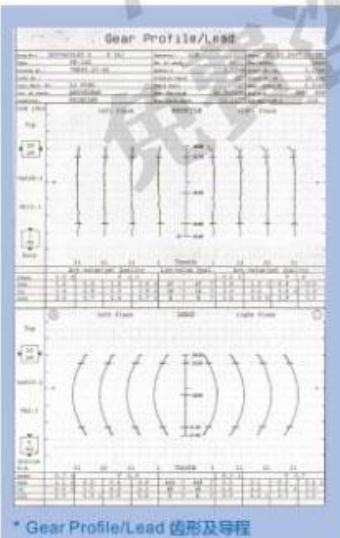

* Gear Profile/Lead 齿形及导程

ATG智造 慧及全球

QC Management

品控管理

以科技为动力，以质量求生存。
Powered by technology, Survival by the quality

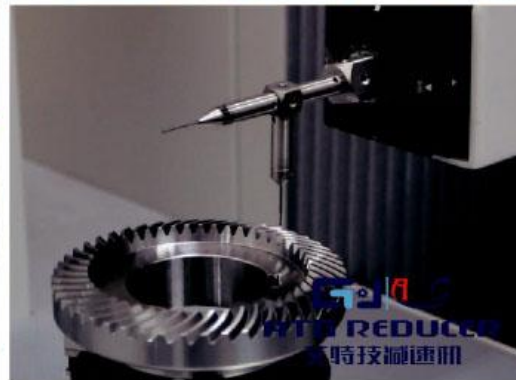

品质铸就辉煌

ATG

ATG智造 慧及全球



ATG智造 慧及全球

THE PURSUIT OF EXCELLENCE CREATE A WORLD BRAND

追求卓越品质 创造世界品牌



CE Certification

UL Certification

ISO 9001:2008

ISO 14001:2004



China Compulsory Certification (CCC)



Planetary Gearhead PHL Series China SIPO Patent



ISO9001



ISO14001



CULUS
Cert.No.E209009



美国、欧盟、中国、台湾、韩国、菲律宾、越南、马来西亚、新加坡等地区商标注册

The United States, European Union, China, Taiwan, Korea, Philippines, Vietnam, Malaysia, Singapore ...etc. trade mark certifications.

GJ ATG
ATG REDUCER
艾特技减速机

● PLANETARY GEARBOX OPERATION MANUAL 行星式减速机操作说明书

1.NOTE 注意事项

1.1 Preparation before installation 安装前准备

- 使用前请熟读“操作说明书”，若因人为原因、非产品本身原因或天灾发生等因素而导致不良或损坏，在操作时违反本说明书所示内容而造成的损害，或未依照原本设计之使用方式及非经由本公司进行的改装及维修所造成的故障，本公司将不承担任何赔偿责任，特此声明，敬请谅解。
Please read this operation manual before using this gearbox. Any problems caused by inappropriate operation contrary with the manual, or damage caused by natural disasters, or restructure the gearbox without our permission, Junyi will not hold any responsibility nor will the gearbox be cover by warranty.
- 本公司的产品保固期间为购买产品后一年内，保固期限内，若产品因非人为因素而发生故障，客户将产品寄回，本公司免费更换受损零件
Warranty start within one year after purchase the gearbox. Within warranty period, if gearbox damage is not caused by operation error nor by natural disaster, then please send back the gearbox, we should replace the damage.
- 减速机之安装、拆卸、保养、须由专业技术人员进行之。
Installation, disassemble, maintenance on the gearbox, needed to be performing by trained technicians.
- 依据安装环境之通风状况，长时间连续运转下可能使得减速机温度升高，运转中与刚停机后请避免直接碰触减速机。
According to the application and operation environment, the gearbox temperature might be raising after period of running. Please do not touch the gearbox directly during operation, or right off from operation.
- 运转中请勿接触任何旋转中之部件，减速机安装完毕后请务必将侧面的塞头回塞，以避免细小物品掉入减速机中。
Do not touch any rotating components when the gearbox is running. Ensure that the plugs of the gearbox were inserted after installation. Avoid any small object fall into the gearbox.
- 减速机为精密零组件，安装过程中，请勿以软锤或者工具敲击减速机本体，以避免影响运转精度。
Handle the gearbox gently during installation, do not knock the gearbox by any tool, to avoid the influence of running accuracy.
- 请勿对减速机进行拆解或改造，否则有可能受伤或造成设备受损。
Do not disassemble or modify gearbox to prevent injury or equipment damage.
- 减速机为密封式设计，油品属半固态高级合成油，不需换油。
Synthetic lubricant is sealed in gear there is no need to change lubricant.

1.2 Installation environment limitation 安装环境的限制

减速机必须依据下列条件安装，不符合下列之安装条件及使用环境将会损害到本产品，不在保固范围内。
Gearbox must be installed under following terms to prevent damages which are not covered by warranty.

- 本产品之设计或制造，为使用装配于其他之机械设备上。
Gearbox is designed or manufactured, to be used in the other of mechanical equipment assembly.
- 周围使用温度-10°C ~ +90°C。
Operate temperature is between -10 °C to + 90 °C.
- 高度：不可超过海平面1000公尺。
Operate altitude may not be higher than 1000m above sea-level
- 避免连续性震动或撞击。
Avoid continuity vibration or hit.
- 避免将减速机使用于可燃气体或腐蚀气体之环境。
Avoid Gearbox used in flammable gas or corrosion gas environment.
- 湿度：不可超过85%，以避免水气凝结。
Humidity: no more than 85%, in order to avoid condensation.
- 避免阳光直射，灰尘堆积。
Avoid direct sunlight, dust accumulation.
- 避免水或油的喷溅。
Avoid water or oil splashed.
- 使用于良好通风之场所。
Used in good ventilated place.

2. Gearbox Introduction 减速机介绍

减速机分为入力端与出力端，入力端用于安装伺服马达，出力端用于安装在所需传动的设备上。

As shown below, the input side is for installing the servo motor and the output is mounted to application equipment.

Output
出力端

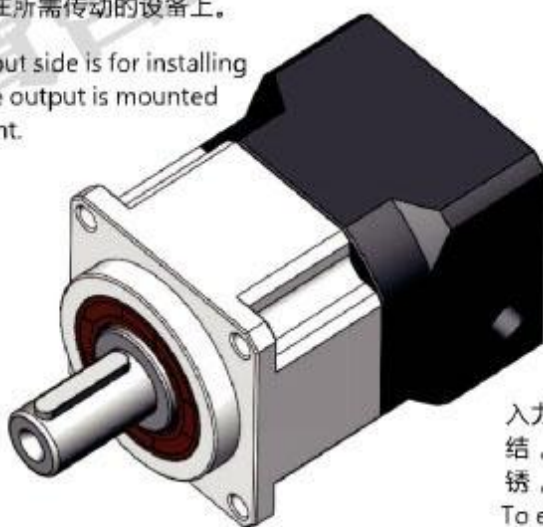

Input
入力端

入力端与出力端分别与伺服马达以及应用端连接，在使用前必须小心保护，避免刮伤或者生锈，影响安装精度，造成运转不顺畅。

To ensure the product performance, both the input and output ends must be protected carefully to avoid any damage and cause improper operation.

● SELECTION OF THE OPTIMUM GEARBOX

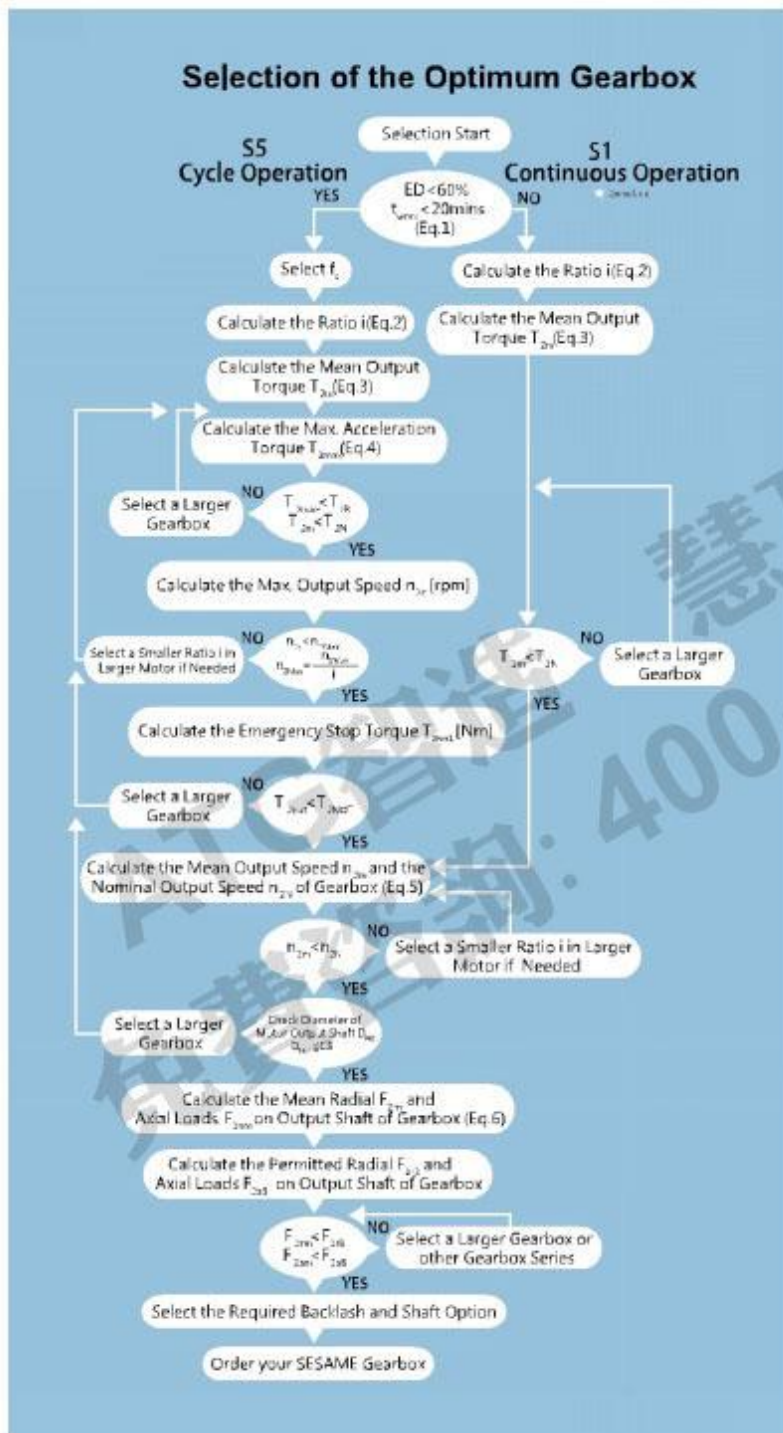

Recommended (for S5 Cycle Operation)
 The general design is given for $\frac{J}{J_m} \leq 4 \times J_s$
 The optimal design is given for $\frac{J}{J_m} \leq J_s$

J_s Load Inertia
 J_m Motor Inertia

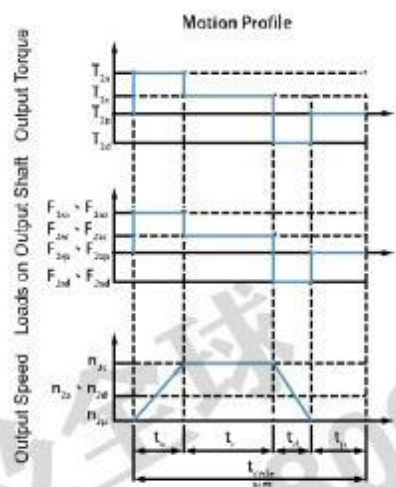

1. $ED = \frac{t_{total}}{t_{cycle}} \times 100\%$, $t_{total} = t_a + t_c + t_d$
 Index : a. Acceleration, c. Constant, d. Deceleration, p. Pause (Eq.1)

2. $i = \frac{n_m}{n_{work}}$
 n_m Output Speed of the Motor
 n_{work} Working Speed (Eq.2)

3. $T_{2m} = 3 \sqrt{\frac{n_{2a} \times t_a \times T_{2a}^3 \times n_{2c} \times t_c \times T_{2c}^3 + n_{2d} \times t_d \times T_{2d}^3}{n_{2a} \times t_a + n_{2c} \times t_c + n_{2d} \times t_d}}$ (Eq.3)

4. $T_{2max} = T_{2m} \times i \times f_s \times \eta$
 Where f_s is

f_s	No. of Cycles / hr
1.0	0 ~ 1,000
1.1	1,000 ~ 1,500
1.3	1,500 ~ 2,000
1.6	2,000 ~ 3,000
1.8	3,000 ~ 5,000

T_{2m} Max. Output Torque of the Motor
 η Efficiency of the Gearbox (Eq.4)

5. $n_{2a} = n_{2d} = \frac{1}{2} \times n_{2c}$
 $n_{2m} = \frac{n_{2a} \times t_a + n_{2c} \times t_c + n_{2d} \times t_d}{t_a + t_c + t_d}$
 $n_{2n} = \frac{n_{2m}}{i}$ (Eq.5)

6. $F_{2m} = 3 \sqrt{\frac{n_{2a} \times t_a \times F_{2am}^2 \times n_{2c} \times t_c \times F_{2cm}^2 + n_{2d} \times t_d \times F_{2dm}^2}{n_{2a} \times t_a + n_{2c} \times t_c + n_{2d} \times t_d}}$
 $F_{2am} = 3 \sqrt{\frac{n_{2a} \times t_a \times F_{2ap}^2 \times n_{2c} \times t_c \times F_{2cp}^2 + n_{2d} \times t_d \times F_{2dp}^2}{n_{2a} \times t_a + n_{2c} \times t_c + n_{2d} \times t_d}}$ (Eq.6)

● 减速机的选用

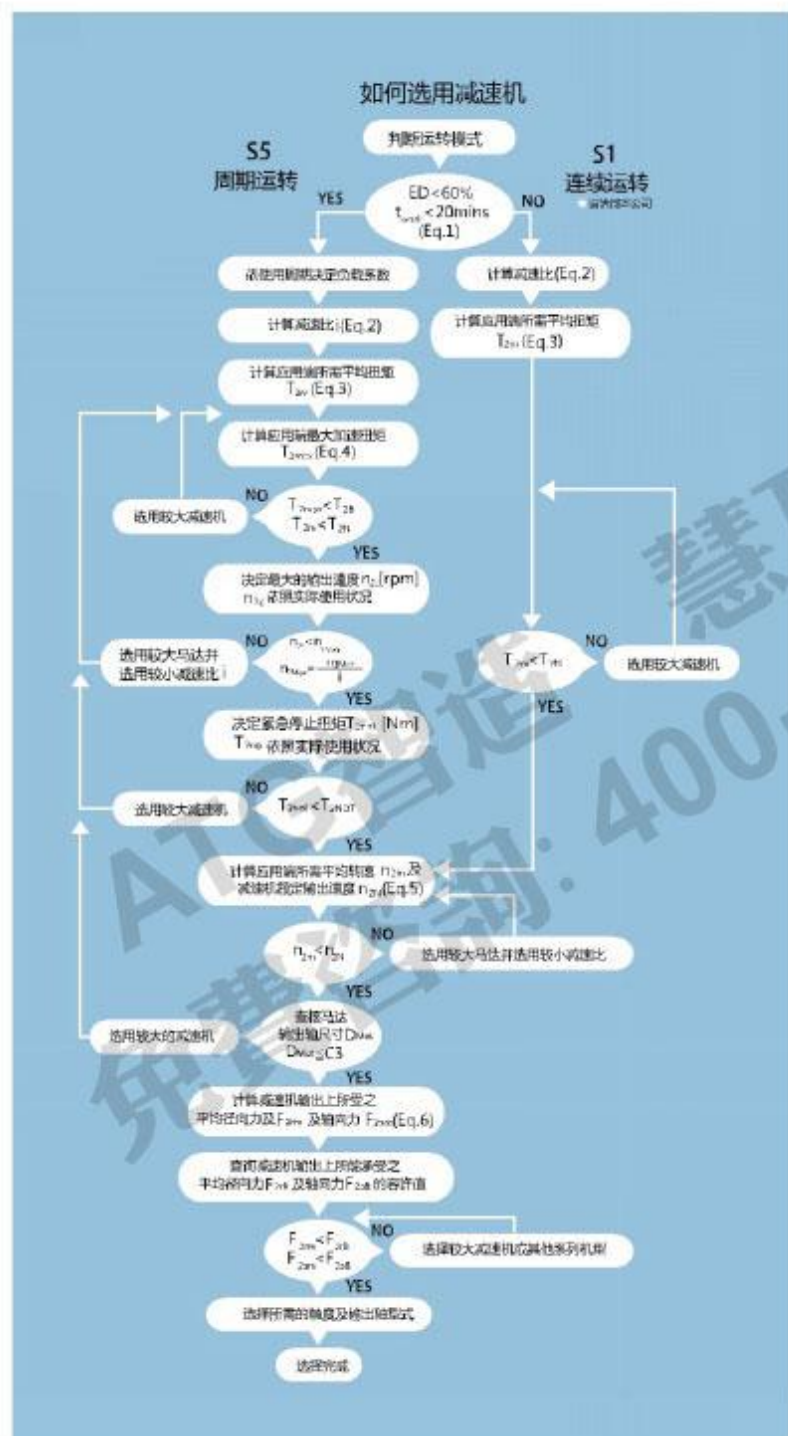

应用端运动模式

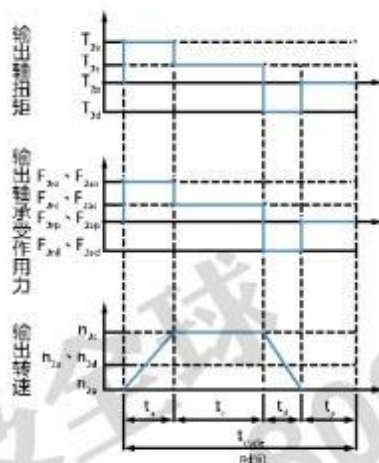

$$1. ED = \frac{t_{work}}{t_{cycle}} \times 100\%, t_{work} = t_a + t_c$$

下标说明: a. 加速, c. 等速
d. 减速, p. 停止 (Eq.1)

$$2. i \leq \frac{n_m}{n_{work}}$$

n_m 马达输出速度
 n_{work} 实际应用速度 (Eq.2)

$$3. T_{2av} = 3 \sqrt{\frac{n_{2a} \times t_a \times T_{2a}^2 + n_{2c} \times t_c \times T_{2c}^2 + n_{2d} \times t_d \times T_{2d}^2}{n_{2a} \times t_a + n_{2c} \times t_c + n_{2d} \times t_d}}$$

(Eq.3)

$$4. T_{2max} = T_{2a} \times i \times f_l \times \eta$$

f_l 负载系数

f_l	周期次数/小时
1.0	0 ~ 1,000
1.1	1,000 ~ 1,500
1.3	1,500 ~ 2,000
1.6	2,000 ~ 3,000
1.8	3,000 ~ 5,000

T_{2a} 马达最大输出扭矩
 η 减速机运转效率 (Eq.4)

$$5. n_{2av} = n_{2c} = \frac{1}{2} \times n_{2c}$$

$$n_{2m} = \frac{n_{2a} \times t_a + n_{2c} \times t_c + n_{2d} \times t_d}{t_a + t_c + t_d}$$

$$n_{2a} = \frac{n_{2m}}{i}$$

(Eq.5)

$$6. F_{2ax} = 3 \sqrt{\frac{n_{2a} \times t_a \times F_{2ax}^2 + n_{2c} \times t_c \times F_{2ax}^2 + n_{2d} \times t_d \times F_{2ax}^2}{n_{2a} \times t_a + n_{2c} \times t_c + n_{2d} \times t_d}}$$

$$F_{2ax} = 3 \sqrt{\frac{n_{2a} \times t_a \times F_{2ax}^2 + n_{2c} \times t_c \times F_{2ax}^2 + n_{2d} \times t_d \times F_{2ax}^2}{n_{2a} \times t_a + n_{2c} \times t_c + n_{2d} \times t_d}}$$

(Eq.6)

行星系列之减速机

一起的应托重量进行合以下公式

$$\frac{1}{P} \leq 4 \times X_1$$

适当的应托重量应符合以下公式

$$\frac{1}{P} \leq 1$$

$\frac{1}{P}$ 应托重量
 $\frac{1}{P}$ 应托重量

● CODING SYSTEM 型号定义



- P** 行星式减速机 (Planetary)
- G** 等级 (Grade)
 - H: 极精密斜齿型 Premium Type Helical Series
 - G: 精密型 Precision Series
 - E: 实用型 Standard Series
- L** 本体与连结方式 (Connection)
 - L: 方形有法兰面 Square Housing with Flange
 - C: 圆形无法兰面 Round Housing without Flange
 - E: 圆形有法兰面 Round Housing with Flange
 - F: 圆盘连结型 Plate Type
 - H: 方形法兰面斜齿型 (适用于等级G精密型行星式减速机) Square Flange Helical Gear (Square Flange Helical Gear for G Grade (Precision Series) Only)
 - RH: 直角斜齿型 Right Angle Helical Gear
 - FR: 圆盘连结直角型 Output Flange Right Angle Type

(旧款系列)

- GX** X: 直齿分离型方法兰面
- BL** BL: 直齿转角轴输出型
- KS** KSB: 斜齿轴输出型
- KS** KSBL: 斜齿转角轴输出型
- SB** SB: 斜齿轴输出分体型

- 60** 框号 (Size) 42:| 42 60:| 60 90:| 90 115:| 115 142:| 142 180:| 180 220:| 220
- I** 减速比 单节式 Single Stage: 3, 4, 5, 6, 7, 8, 9, 10
- 30** (Speed Reduction Ratio) 双节式 Double Stage: 12, 15, 20, 25, 30, 35, 40, 45, 50, 60, 70, 80, 90, 100
- I** 多节式 Multi-Stage: 125-1000
- P1** 背隙 (Backlash) P0: 超精密级 Micro Backlash
- I** P1: 精密等级 Precision Backlash
- Y** P2: 标准背隙 Standard Backlash
- I** 特殊规格 (Customer Specification)
- MOTOR** 马达型号 (Motor Model)

▶ 马达与减速机组合方法 CONNECTION OF MOTOR & GEARHEAD

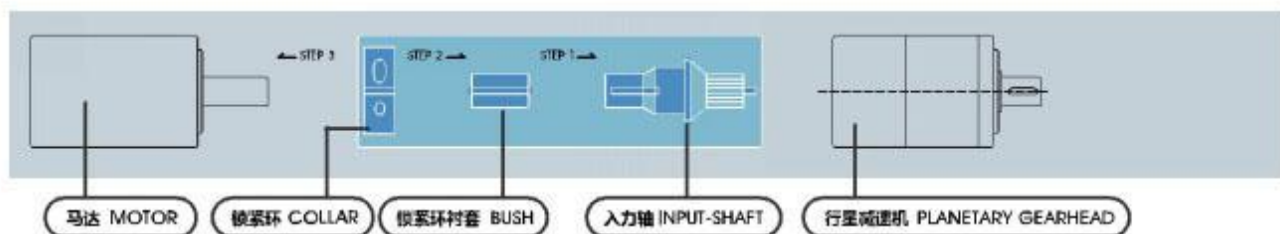

马达 MOTOR

锁紧环 COLLAR

锁紧环衬套 BUSH

输入轴 INPUT-SHAFT

行星减速机 PLANETARY GEARHEAD

不一样的马达轴
用不一样的衬套
Use different bushes for
different motor-shafts.

连接板上与马达连接的孔位，可由使用者
提供资料，再由本公司代为加工
At the customer's request, we may special
process the connection hole where the
backof joins the motor.

- 锁紧环、锁紧环衬套、输入轴与马达稳固组合后，请谨慎与行星式减速机结合后，以防止伤及减速机的内部结构。
After the collar, the bush, and the input shaft are securely assembled with the motor, please join the parts with the planetary gearhead cautiously with a slight clockwise and/or counter-clockwise motion, until the planetary gearhead engages the input shaft.

* 在正常的使用状态下，本公司出厂的产品保固一年或20,000小时，以先到期为准。

Under normal usage and loading, our products come with a one-year or 20,000-hour limited warranty, whichever comes first.

● FILL IN DATA OF MOTOR 客户填写资料

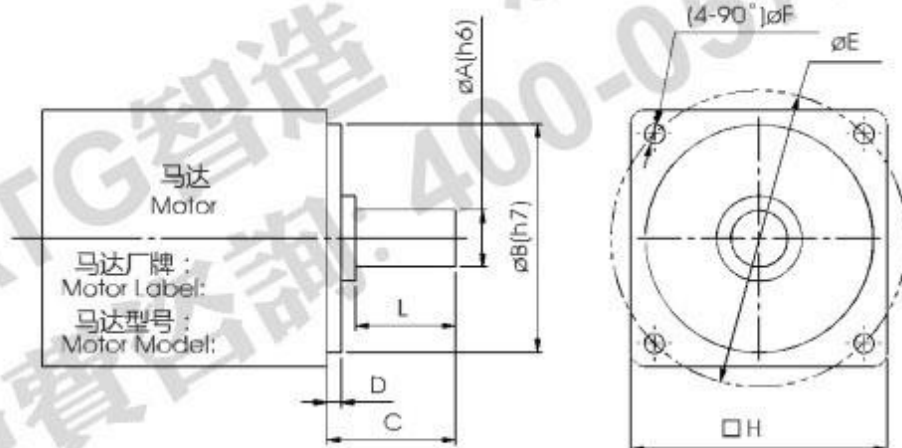

▶ 规格 SPECIFICATIONS

Motor Shaft Dia.	Flange Dia.	Motor Shaft Length	Flange Height	P.C.D of Bore	Bore Dia.	Motor Flange Square	Actual Length of Motor Shaft	Backlash
马达轴外径	马达凸缘外径	马达轴长度	马达凸缘高度	螺丝孔中心距	螺丝孔直径	马达面尺寸	马达轴有效长	要求背隙
$\phi A(h6)$	$\phi B(h7)$	C	D	ϕE	ϕF	$\square H$	L	P0/P1/P2

* 本公司生产行星式减速机皆经过专属配对加工，保证寿命超长并确保背隙精度不变，荣获国内外知名精密机械或半导体大厂选用，值得信赖。

*JUNYI Planetary Gearheads are produced under strickly exclusive pairing process to ensure accuracy and lifespan.

产品概述 / PRODUCTS OVERVIEW

产品特点/products features

精密行星齿轮减速机是我公司自主研发的新一代实用性产品，融合了国内外先进的技术，具有以下一些主要特点:

- 1.低噪音: 低于65db。
- 2.低背隙: 单级可达3弧分内，双级可达5弧分内。
- 3.高效率: 单段式在95%以上，双段式在92%以上。
- 4.高输入转速: 可达8000RPM。
- 5.高扭矩: 比一般标准行星减速机扭矩高。
- 6.高稳定性: 采用高强度合金钢材，整颗齿轮经硬化处理，非只有表面硬化，确保使用寿命及长期使用仍保持最初的精密度。
- 7.高减速比: 采用模组化设计，行星齿箱可相互连结，速比可达1/1000以上。

Precision planetary gear reducer is a new-generation of product developed by our company,with a compromise of advanced technology both at home and abroad,its main features are as follows:

- 1.Low Noise: Under 65db.
- 2.Low Backlash: Backlash is under 3 arcmin.Backlash for 2-stage speed reduction is within 5 arcmin.
- 3.High Efficiency: Efficiency for 1-stage model exceeds 95% ,For 2-stage model exceeds 92%.
- 4.High Input Speed: Input speed allows for up to 8000 RPM.
- 5.High Torque: Higher torque output than that of conventional planetary gear reducers.
- 6.High Stability: Employs high tensile strength alloy steel.Gear hardening is made for the entire gear instead of only surface hardening,which extends gear service life and maintain high accuracy as new after a long period of operation.
- 7.High Speed Reduction Ratio: The gear reducer is a modular deign.The planetary gear box can be connected.Speed reduction ratio is over 1/1000.

产品用途/Precision usage

精密行星齿轮减速机被广泛应用于以下领域：

- 1.航空航天、军事产业。
- 2.医疗卫生、电子信息技术产业。
- 3.工业机器人、生产自动化、数控机床制造产业。
- 4.汽车制造、纺织、印刷、食品、冶金、环保工程、仓储物流等产业。

Precision Planetary Gear Reducer is widely used in the following domain:

1. Aerospace, military industry.
2. Medical health, electronic information industry.
3. Industrial robots, Production automation, CNC machine tool manufacturing industry.
4. Motor, textile, printing, food, metallurgical, environmental protection engineering, warehouse logistics industr.

产品特性 / PRODUCTS FEATURES



齿轮材料采用优质合金钢，经碳-氮共渗处理，从而获得最佳的耐磨性和耐冲击韧性。

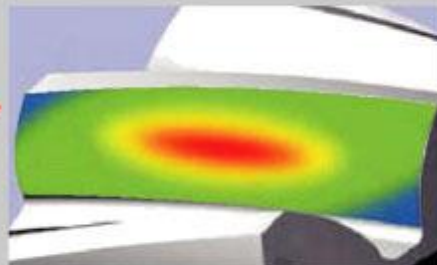

利用ANSYS技术对齿轮强度进行有限元分析，同时对齿面作齿形及导程修整，以减低齿轮啮合的冲击和噪音，增加齿轮系的使用寿命。



输出行星架采用一体式（双支撑）的结构设计，前后轴承大跨距分布于箱体内，形成稳定的一体式结构，以确保较高的扭转刚性和精度。

PGH系列为例



齿圈与输出壳体采用一体化设计，采用优质钢材，经热锻成形，从而获得较高的材料密度。一体化设计能保证所有几何尺寸一次性加工完成，与其它内嵌式、夹装式等结构相比具有更高的精度和强度。



输入轴与锁紧装置采用一体化设计，双螺栓对称分布，达到动平衡的同时，通过双螺栓的强力锁死，有效防止电机轴传动打滑，实现高精度零背隙的动力传送。



品质铸就辉煌

ATG

ATG智造 慧及全球



慧及全球
72-809

免費

PGL

SERIES



WISDOM MADE

IN ATG

WISDOM THE WORLD

ATG 智造 慧及全球

减速机性能资料 / GEAR BOX PERFORMANCE INFORMATION

规格	级数	减速比 ¹	PGL42	PGL60	PGL90	PGL115	PGL142	PGL180	PGL220	
额定输出扭矩 T _{2N}	Nm	1	3	20	55	130	208	342	588	1,140
			4	19	50	140	290	542	1,050	1,700
			5	22	60	160	330	650	1,200	2,000
			7	19	50	140	300	550	1,100	1,800
			8	17	45	120	260	500	1,000	1,600
			10	14	23	48	140	370	520	1,220
		2	12	20	55	130	208	342	588	1,140
			15	20	55	130	208	342	588	1,140
			20	19	50	140	290	542	1,050	1,700
			25	22	60	160	330	650	1,200	2,000
			30	22	60	160	330	650	1,200	2,000
			35	22	60	160	330	650	1,200	2,000
			40	22	60	160	330	650	1,200	2,000
			50	22	60	160	330	650	1,200	1,900
			70	19	35	140	300	550	1,100	1,800
80	17	35	120	260	500	1,000	1,600			
100	14	23	48	140	370	520	1,220			
最大输出扭矩 T ₂	Nm	1,2	3~100			3倍额定输出扭矩				
额定输入转速 n ₁	rpm	1,2	3~100	5,000	5,000	4,000	4,000	3,000	3,000	2,000
最大输入转速 n ₁	rpm	1,2	3~100	10,000	10,000	8,000	8,000	6,000	6,000	4,000
精密背隙 P1	arcmin	1	3~10	≤3	≤6	≤6	≤6	≤6	≤6	≤6
		2	12~100	≤5	≤8	≤8	≤8	≤8	≤8	≤8
标准背隙 P2	arcmin	1	3~10	≤5	≤8	≤8	≤8	≤8	≤8	≤8
		2	12~100	≤7	≤10	≤10	≤10	≤10	≤10	≤10
扭转刚性	Nm/arcmin	1,2	3~100	3	7	14	25	50	145	225
容许径向力 F _{ra} ²	N	1,2	3~100	780	1,530	3,250	6,700	9,400	14,500	50,000
容许轴向力 F _{sa} ²	N	1,2	3~100	350	630	1,300	3,000	4,000	6,200	35,000
容许轴向力 F _{sa} ¹	N	1,2	3~100	390	765	1,625	3,350	4,700	7,250	25,000
使用寿命	hr	1,2	3~100			20,000	*			
效率 η	%	1	3~10							
		2	12~100							
重量	kg	1	3~10	0.5	1.3	3.7	7.8	14.5	29	48
		2	12~100	0.8	1.9	4.1	9	17.5	33	60
使用温度	°C	1,2	3~100				-10°C~+90°C			
润滑		1,2	3~100				合成润滑油			
防护等级		1,2	3~100				IP65			
安装方向		1,2	3~100				任意方向			
噪音值 (n=3000rpm)	dB	1,2	3~100	≤56	≤58	≤60	≤63	≤65	≤67	≤70

减速机转动惯量

规格	级数	减速比 ¹	PGL42	PGL60	PGL90	PGL115	PGL142	PGL180	PGL220	
转动惯量 J ₁	kg·cm ²	1	3	0.03	0.16	0.61	3.25	9.21	28.98	69.61
			4	0.03	0.14	0.48	2.74	7.54	23.67	54.37
			5	0.03	0.13	0.47	2.71	7.42	23.29	53.27
			7	0.03	0.13	0.45	2.62	7.14	22.48	50.97
			8	0.03	0.13	0.44	2.58	7.07	22.59	50.84
			10	0.03	0.13	0.44	2.57	7.03	22.51	50.56
		2	12	0.03	0.03	0.13	0.47	2.71	7.42	23.29
			15	0.03	0.03	0.13	0.47	2.71	7.42	23.29
			20	0.03	0.03	0.13	0.47	2.71	7.42	23.29
			25	0.03	0.03	0.13	0.47	2.71	7.42	23.29
			30	0.03	0.03	0.13	0.47	2.71	7.42	23.29
			35	0.03	0.03	0.13	0.47	2.71	7.42	23.29
			40	0.03	0.03	0.13	0.47	2.71	7.42	23.29
			50	0.03	0.03	0.13	0.44	2.57	7.03	22.51
			70	0.03	0.03	0.13	0.44	2.57	7.03	22.51
80	0.03	0.03	0.13	0.44	2.57	7.03	22.51			
100	0.03	0.03	0.13	0.44	2.57	7.03	22.51			

减速比 (i=N₁/N₂)
 连续运转时使用寿命二分之一。

2. 输出转速 100 rpm 时，作用于输出轴中心位置。

减速机输出轴之容许径向力及轴向力

REDUCER OUTPUT SHAFT OF THE PERMISSIBLE RADIAL FORCE AND SHAFT AND FORCE

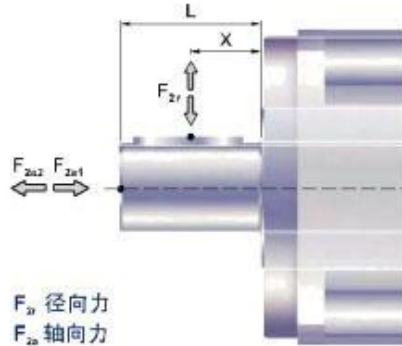

F_r 径向力
 F_{ax} 轴向力

减速机输出轴所能承受之最大径向力及轴向力，端视内部支撑轴承之设计，减速机采用大尺寸的轴承及较大跨距的设计，其能承受更大的径向及轴向负荷。

容许径向力 F_{r0} [N] 施力于轴中心位置

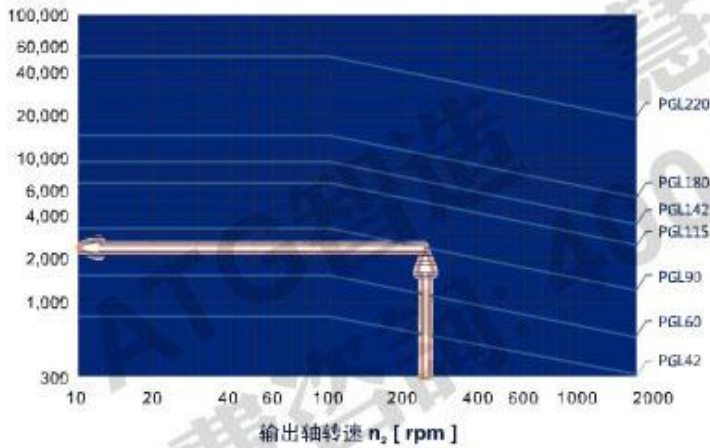

位置负荷系数 k_x

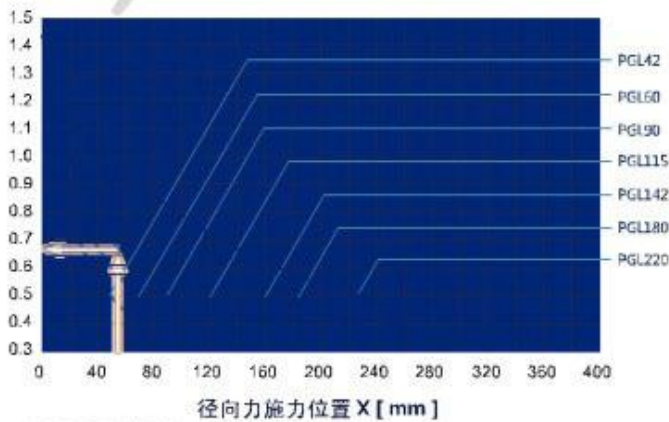

连续运转降低使用寿命二分之一。

当径向力 F_r 施力于轴中心位置时 $X=0$ 时，不同规格之减速机在不同输出转速适用下使用寿命为 20,000h 时，并知该型之容许径向力 F_{r0} ，则可求出该减速机承受之容许轴向力 F_{ax} 为：
 $F_{ax} = 0.2 \times F_{r0}$
 $F_{ax} = 0.1 \times F_{r0}$

当径向力 F_r 施力不在轴中心位置时，除知道减速机型号 $X > 1/2L$ 时，所施力量之容许径向力变大，越远离减速机中心 $X > 1/2L$ 时，所施力量之容许径向力则变小，请速参阅本减速机规格及径向力施力位置 X 位置负荷系数 k_x ，再代入下列公式，求出容许轴向力：
 $F_{ax} = k_x \times F_{r0}$
 轴向力：
 $F_{ax} = 0.2 \times F_{r0}$
 $F_{ax} = 0.1 \times F_{r0}$

外形尺寸图表 / OUTLINE DIMENSION SHEET

PGL42-L1

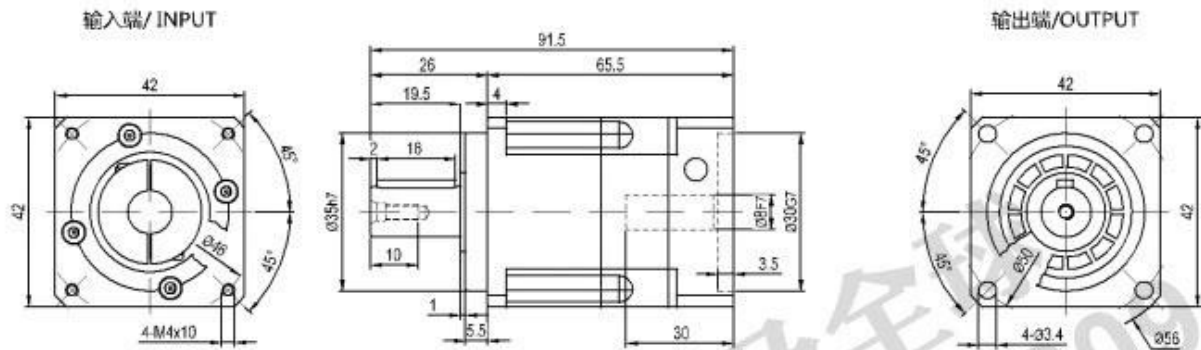

PGL42-L2

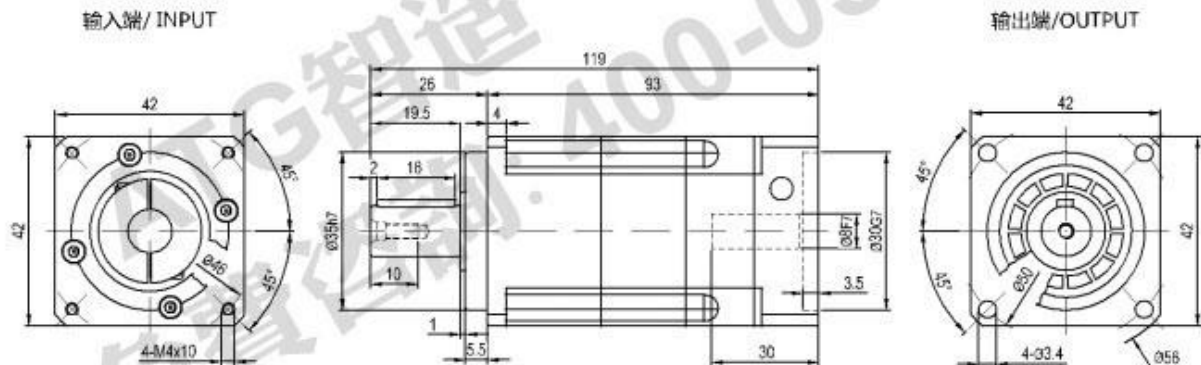

输出轴径/Output Diameter

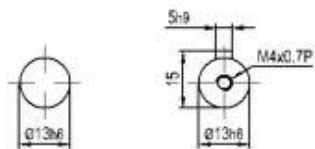

轴型式 S1

轴型式 S2

*输入马达连接板之尺寸, 可根据客户要求单独定做。
*The input motor specific dimensions could be customised.

外形尺寸图表 / OUTLINE DIMENSION SHEET

PGL60-L1

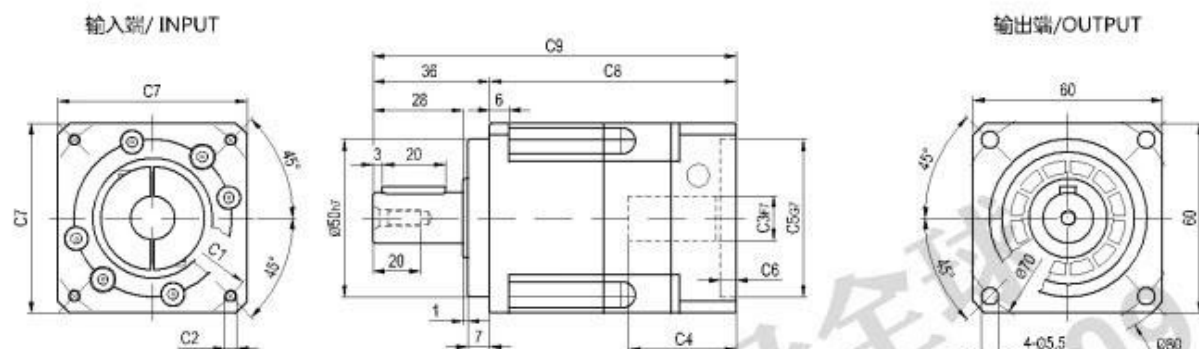

PGL60-L2

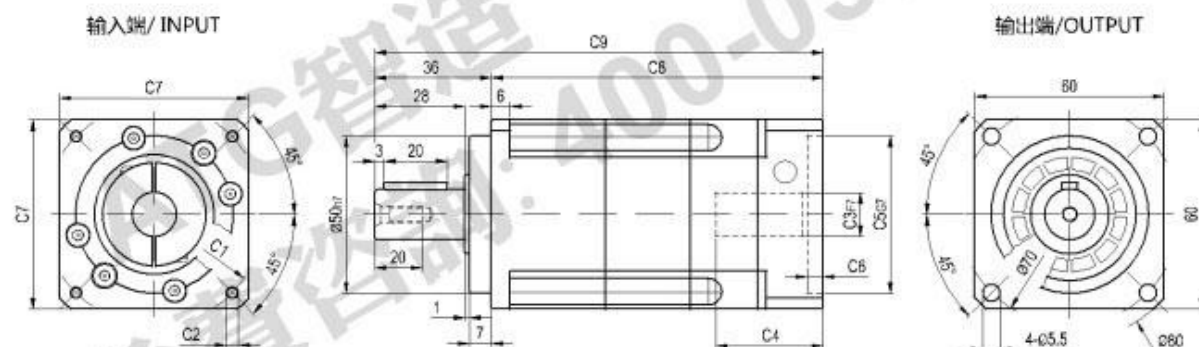

输出轴径/Output Diameter

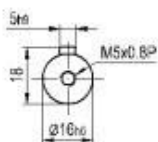

尺寸	C1	C2	C3	C4	C5	C6	C7	C8	C9
PGL60-L1	$\varnothing 70$	4-M4x10, 4-M5x12	$\varnothing 11, \varnothing 14$	34	$\varnothing 50$	5	60	78	114
	$\varnothing 90$	4-M5x12, 4-M6x12	$\varnothing 19$	44	$\varnothing 70$	5	80	88	124
PGL60-L2	$\varnothing 70$	4-M4x10, 4-M5x12	$\varnothing 11, \varnothing 14$	34	$\varnothing 50$	5	60	108	144

* C1-C7是公制标准马达连接板之尺寸, 可根据客户要求单独定做。

* C1-C7are motor(metric standard) specific dimensions, which could be customised.

外形尺寸图表 / OUTLINE DIMENSION SHEET

PGL90-L1

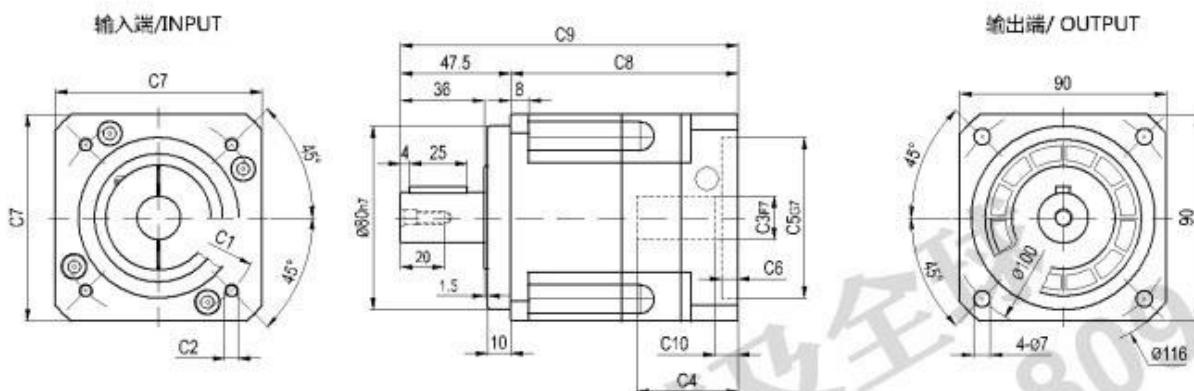

PGL90-L2

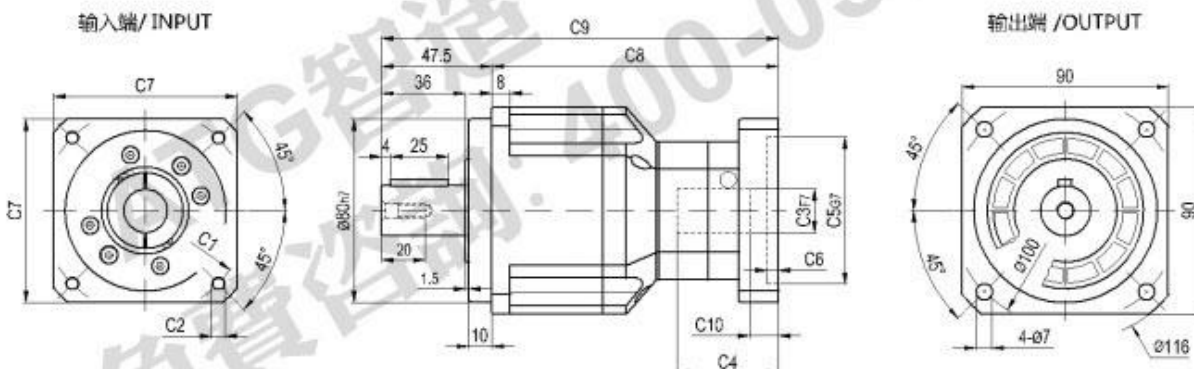

输出轴径/Output Diameter

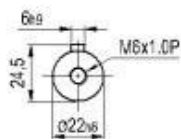

尺寸	C1	C2	C3	C4	C5	C6	C7	C8	C9	C10
PGL90-L1	Ø90	4-M5x12, 4-M6x12	Ø19	44	Ø70	7	90	98.5	146	8
	Ø100	4-M6x12	Ø16	44	Ø80	7	90	98.5	146	7
	Ø115	4-M8x20	Ø19, Ø22	50	Ø95	8	100	104.5	152	13
	Ø145	4-M8x25	Ø19, Ø22	60	Ø95	8	100	114.5	162	23
PGL90-L2	Ø70	4-M4x10, 4-M5x12	Ø11, Ø14	34	Ø50	5	60	117	164.5	5.5
	Ø90	4-M5x12, 4-M6x12	Ø19	44	Ø70	5	80	127	174.5	16.5
	Ø100	4-M6x12	Ø16	38.5	Ø80	5	86	121.5	169	10

* C1-C7是公制标准马达连接板之尺寸, 可根据客户要求单独定做。

* C1-C7are motor(metric standard) specific dimensions, which could be customised.

外形尺寸图表 / OUTLINE DIMENSION SHEET

PGL115-L1

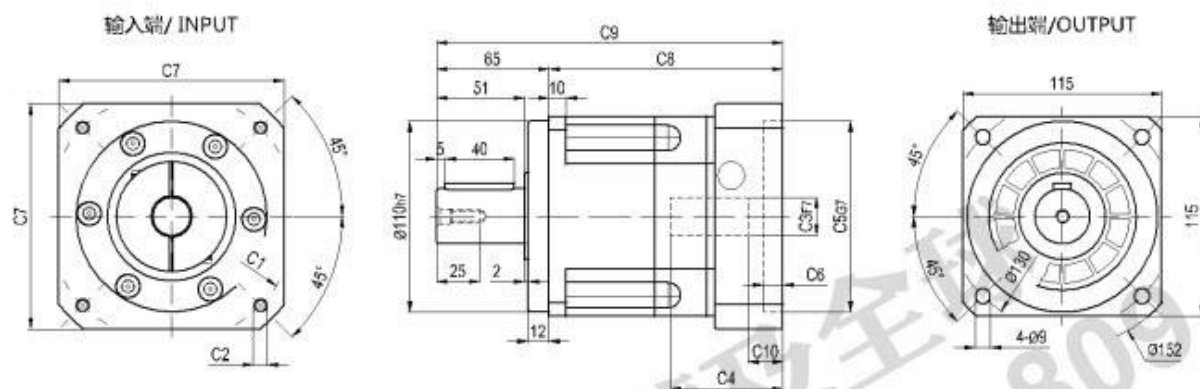

PGL115-L2

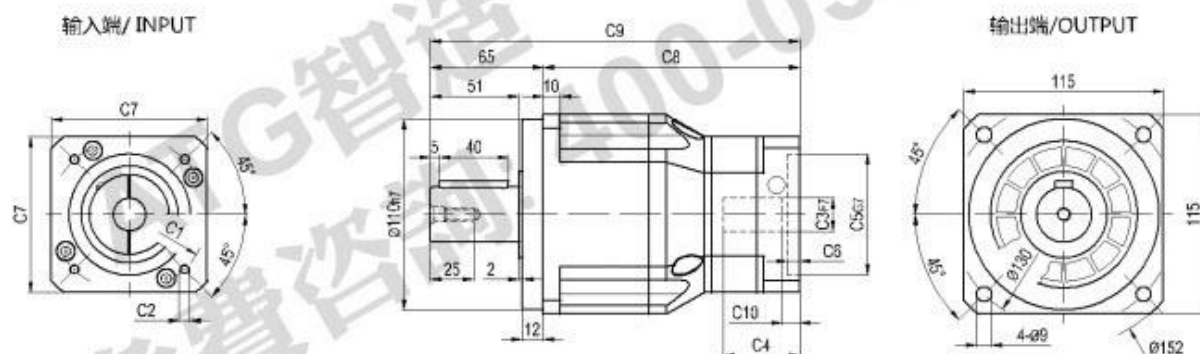

输出轴径/Output Diameter

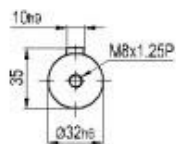

尺寸	C1	C2	C3	C4	C5	C6	C7	C8	C9	C10
PGL115-L1	$\varnothing 145$	4-M8x25	$\varnothing 19, \varnothing 22, \varnothing 24$	65.5	$\varnothing 110$	11	130	135	200	19
	$\varnothing 200$	4-M12x28	$\varnothing 35$	81	$\varnothing 114.3$	6	180	150.5	215.5	35.5
PGL115-L2	$\varnothing 90$	4-M5x12, 4-M6x12	$\varnothing 19$	44	$\varnothing 70$	7	90	146	211	8
	$\varnothing 100$	4-M6x12	$\varnothing 16$	44	$\varnothing 80$	7	90	146	211	7
	$\varnothing 115$	4-M8x20	$\varnothing 19, \varnothing 22$	50	$\varnothing 95$	8	100	152	217	13
	$\varnothing 115$	4-M8x25	$\varnothing 19, \varnothing 22$	60	$\varnothing 95$	8	100	162	227	23
$\varnothing 145$	4-M8x25	$\varnothing 19, \varnothing 22, \varnothing 24$	60	$\varnothing 110$	8	130	162	227	23	

* C1-C7是公制标准马达连接板之尺寸,可根据客户要求单独定做。

* C1-C7are motor(metric standard) specific dimensions, which could be customised.

外形尺寸图表 / OUTLINE DIMENSION SHEET

PGL142-L1

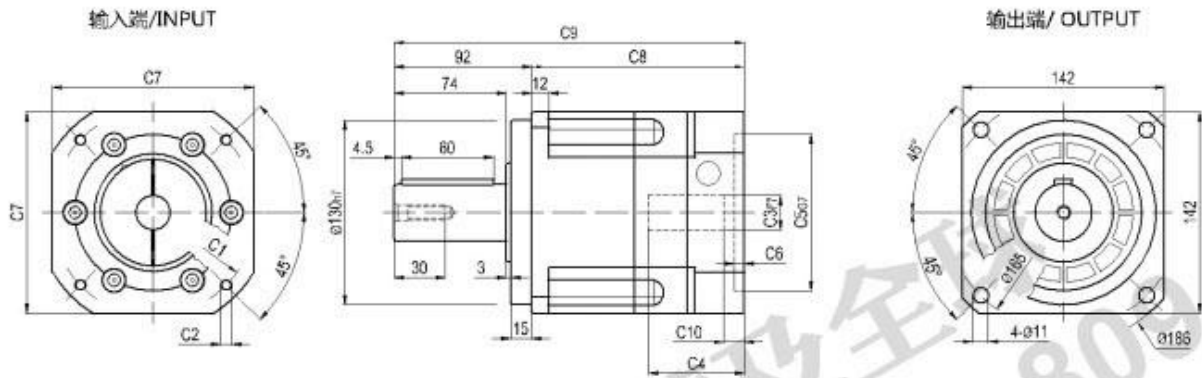

PGL142-L2

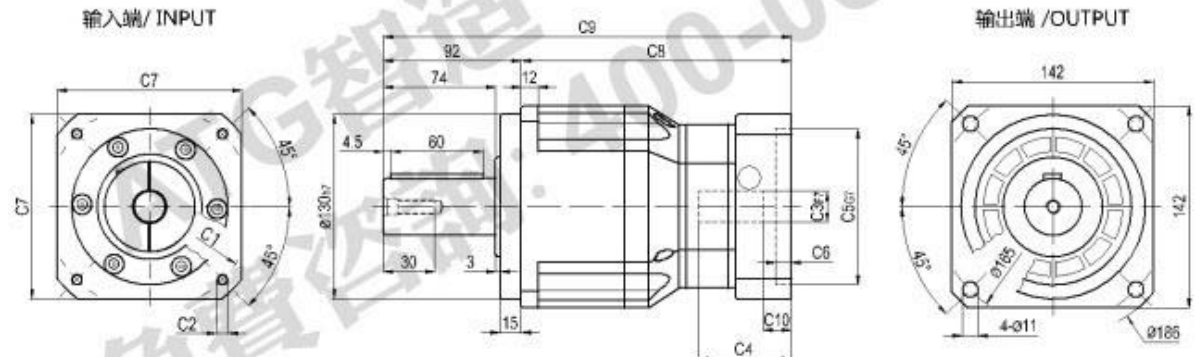

输出轴径/Output Diameter

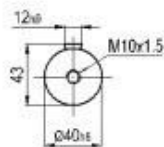

尺寸	C1	C2	C3	C4	C5	C6	C7	C8	C9	C10
PGL142-L1	Ø145	4-M8x25	Ø22, Ø24	69.5	Ø110	7	142	148	240	14.5
	Ø200	4-M12x23	Ø35	85	Ø114.3	8	180	163.5	255.5	30
PGL142-L2	Ø145	4-M8x25	Ø19, Ø22, Ø24	65.5	Ø110	11	130	190.5	282.5	19
	Ø200	4-M12x28	Ø35	81	Ø114.3	6	180	206	298	35.5

* C1-C7是公制标准马达连接板之尺寸,可根据客户要求单独定做。

* C1-C7are motor (metric standard) specific dimensions, which could be customised,

外形尺寸图表 / OUTLINE DIMENSION SHEET

PGL180-L1

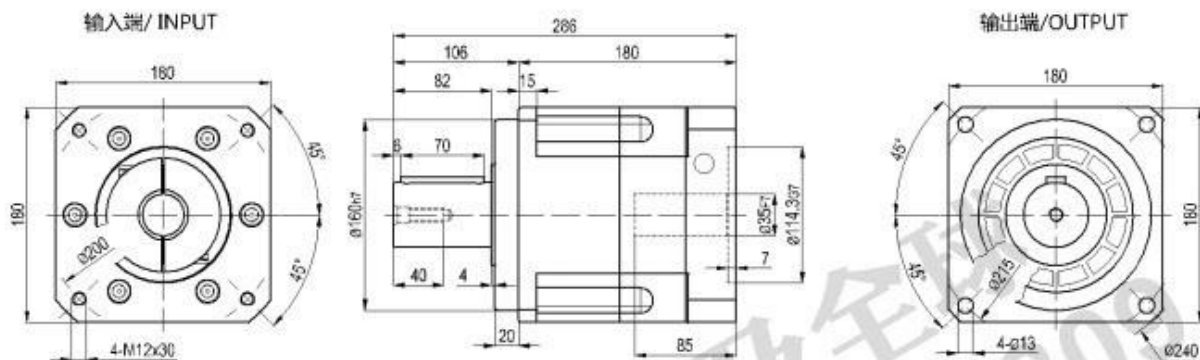

PGL180-L2

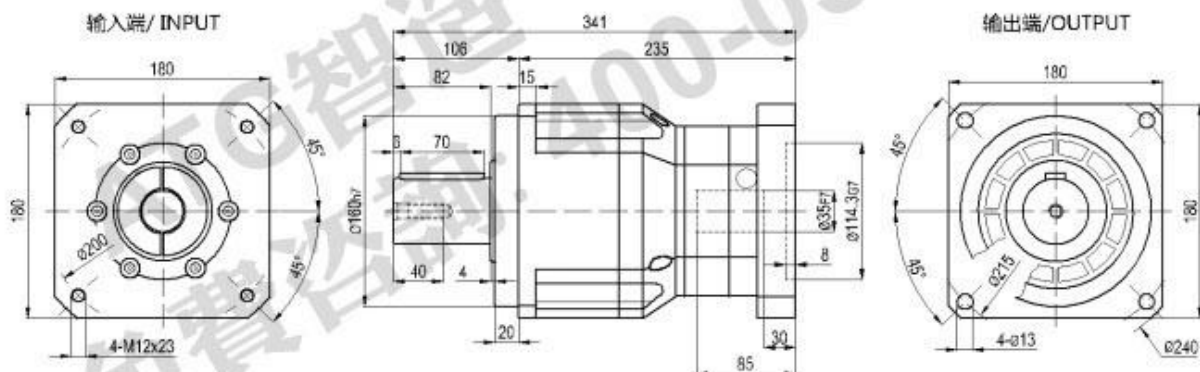

输出轴径/Output Diameter

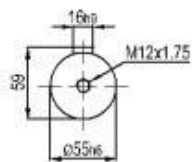

*输入马达连接板之尺寸,可根据客户要求单独定做。

*The input motor specific dimensions could be customised.

外形尺寸图表 / OUTLINE DIMENSION SHEET

PGL220-L1

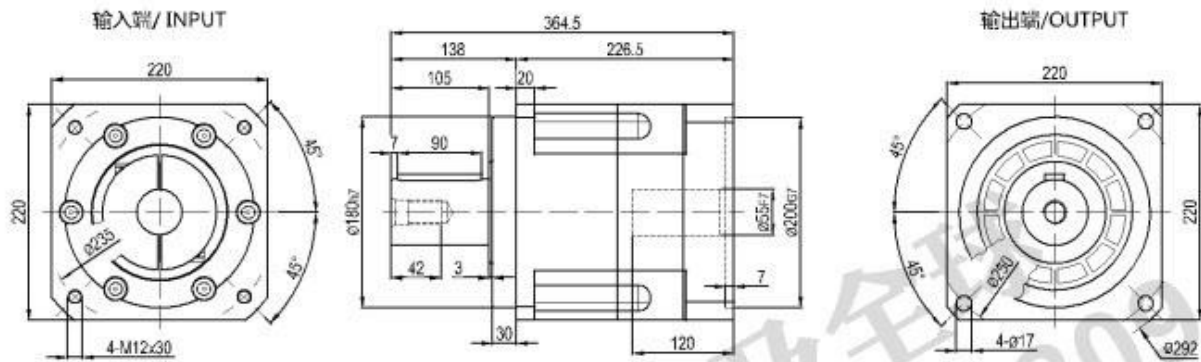

PGL220-L2

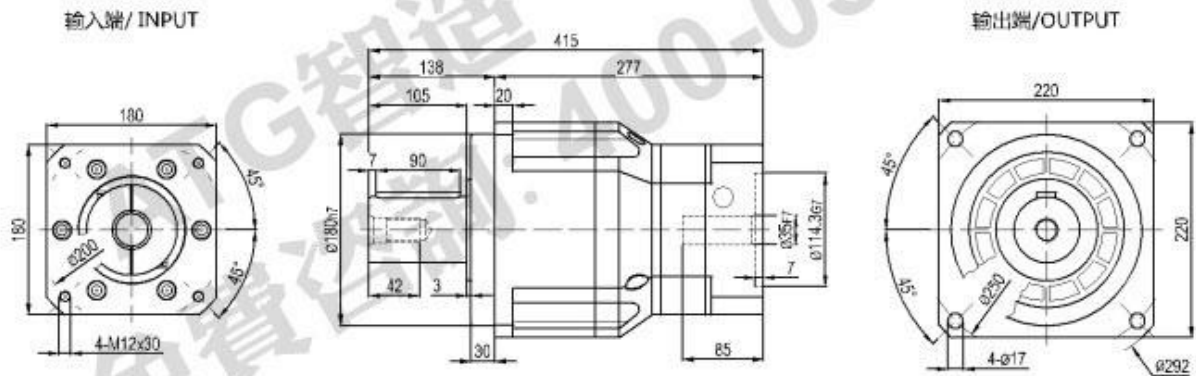

输出轴径/Output Diameter

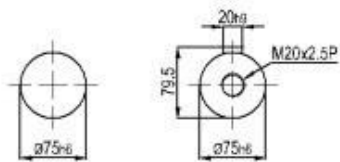

轴型式 S1

轴型式 S2

*输入马达连接板之尺寸,可根据客户要求单独定做。
*The input motor specific dimensions could be customised.

● PLANETARY GEARBOX WITH MOTOR MOUNTING INSTRUCTIONS 行星减速机马达安装说明书

For General Type

1

先确认马达减速机规格是否正确，并将马达与减速机之安装面擦拭干净。

Check the motor and gearbox size. Clean the mounting surface.



2

将连接板上扣式塞头取下，转动马达锁紧环，直到锁紧环螺丝对准塞头孔。

Take off the plug from the bracket. Revolve the set collar until the bolt is aligned with the hole.



3

取下马达上原先的键，如有必要，请安装平衡键。

Remove the key from the motor shaft. Mounting the balance key if necessary.

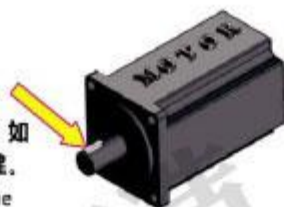

确认马达轴心尺寸，轴心太小选用适当衬套。

Make sure the motor shaft size. Choose the right bushing if necessary.

当马达为平轴状，对准衬套夹缝在平轴中心线，使锁紧环螺丝与平轴面呈垂直。

As installing on flatted shaft, be sure to align the collet gap over the flat and the set collar bolt perpendicular to the flat.

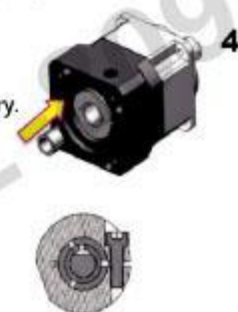

5

以锁紧扭力表建议扭力值的5%，依照1至4顺序，将螺丝轻轻锁上。

Tighten the mounting bolts in 1-4 order with torque wrench to 5% specified torque.



6

马达与减速机务必保持垂直组装，参照锁紧扭力表建议之扭力值，以扭力扳手将马达锁紧环螺丝锁紧。

Install gearbox and motor vertically. Tighten the set collar bolt with torque wrench to specified torque.



7

以锁紧扭力表建议之扭力值，依照1至4顺序，用扭力扳手将螺丝锁紧。

Tighten the mounting bolts in 1-4 order with torque wrench to specified torque.



8

将扣式塞头装回。

Put the plug back.



马达安装说明 / MOTOR INSTALLATION INSTRUCTIONS

表一 马达锁紧螺丝扭力建议表

螺丝尺寸	六角头尺寸 [mm]	强度8.8螺丝之锁紧扭力		强度10.9螺丝之锁紧扭力		强度12.9螺丝之锁紧扭力	
		[Nm]	[In-lbs]	[Nm]	[In-lbs]	[Nm]	[In-lbs]
M3 x 0.5P	2.5	1.3	12	1.8	16	2.1	19
M4 x 0.7P	3	3	27	4.1	37	4.9	44
M5 x 0.8P	4	6.1	55	8.2	73	9.8	87
M6 x 1P	5	11	98	14	124	17	151
M8 x 1.25P	6	25	222	34	302	41	364
M10 x 1.5P	8	49	434	67	594	80	709
M12 x 1.75P	10	85	753	116	1028	139	1232
M14 x 2P	12	137	1214	186	1648	223	1976
M16 x 2P	14	210	1860	286	2534	343	3038

表二 马达锁紧螺丝扭力建议表

减速机型号		马达轴径	螺丝尺寸	六角头尺寸	锁紧扭力	
		[mm]	[mm]	[mm]	[Nm]	[In-lbs]
PGL42	单级	≤12	M3 x 0.5P x 8L	2.5	2.1	19
	双级	≤12	M3 x 0.5P x 8L	2.5	2.1	19
PGL60	单级	≤19	M4 x 0.7P x 12L	3	4.9	44
	双级	≤19	M4 x 0.7P x 12L	3	4.9	44
PGL90	单级	≤24	M5 x 0.8P x 20L	4	9.8	87
	双级	≤19	M4 x 0.7P x 12L	3	4.9	44
PGL115	单级	≤35	M8 x 1.25P x 30L	6	41	364
	双级	≤24	M5 x 0.8P x 20L	4	9.8	87
PGL142	单级	≤38	M10 x 1.5P x 30L	8	80	709
	双级	≤35	M8 x 1.25P x 30L	6	41	364
PGL180	单级	≤50	M12 x 1.75P x 35L	10	139	1232
	双级	≤38	M10 x 1.5P x 30L	8	80	709
PGL220	单级	≤55	M16 x 2P x 40L	14	343	3038
	双级	≤50	M12 x 1.75P x 35L	10	139	1232

备注：螺丝锁紧扭力必须大于上述值。若有需要时，可将锁紧扭力多增加上述建议值之20%，以避免打滑。

Wisdom Made

IN ATG

Wisdom The World

ATG智造 慧及全球



艾特技減速機
ATG REDUCER



ATG 智造 慧及全球
免費諮詢: 400-0572-8099

台灣君益機械股份有限公司

Taiwan JunYi MACHINE & ELECTRIC CO., LTD.

地址：台中市神岡區厚生路699號

Add: No. 699 thick kamiora. Taichung

City District Road

Email: zks@twatg.com

WWW.TWATG.COM